



US 20150060817A1

(19) **United States**
(12) **Patent Application Publication**
SATO et al.

(10) **Pub. No.: US 2015/0060817 A1**
(43) **Pub. Date: Mar. 5, 2015**

(54) **DISPLAY DEVICE**

(71) Applicant: **Japan Display Inc.**, Tokyo (JP)

(72) Inventors: **Toshihiro SATO**, Tokyo (JP); **Ryoichi ITO**, Tokyo (JP)

(73) Assignee: **Japan Display Inc.**

(21) Appl. No.: **14/469,634**

(22) Filed: **Aug. 27, 2014**

(30) **Foreign Application Priority Data**

Aug. 30, 2013 (JP) 2013-179505

Publication Classification

(51) **Int. Cl.**
H01L 27/32 (2006.01)

(52) **U.S. Cl.**

CPC **H01L 27/3253** (2013.01); **H01L 27/323** (2013.01)

USPC **257/40**

(57) **ABSTRACT**

An organic electroluminescent device with a touch sensor including: a first substrate; a second substrate arranged opposite to the first substrate; an organic EL element layer arranged above the first substrate; a first sealing film arranged toward the second substrate of the organic EL element layer, covering the organic EL element layer, and including a first inorganic layer; plural first detection electrodes extending in one direction, and arranged in parallel toward the second substrate of the first sealing film; a second sealing film arranged toward the second substrate of the first detection electrodes, and including a second inorganic layer; plural second detection electrodes extending in another direction different from the one direction, and arranged in parallel toward the second substrate of the second sealing film; and a touch sensor control unit controlling a potential to detect a touch with a display surface.

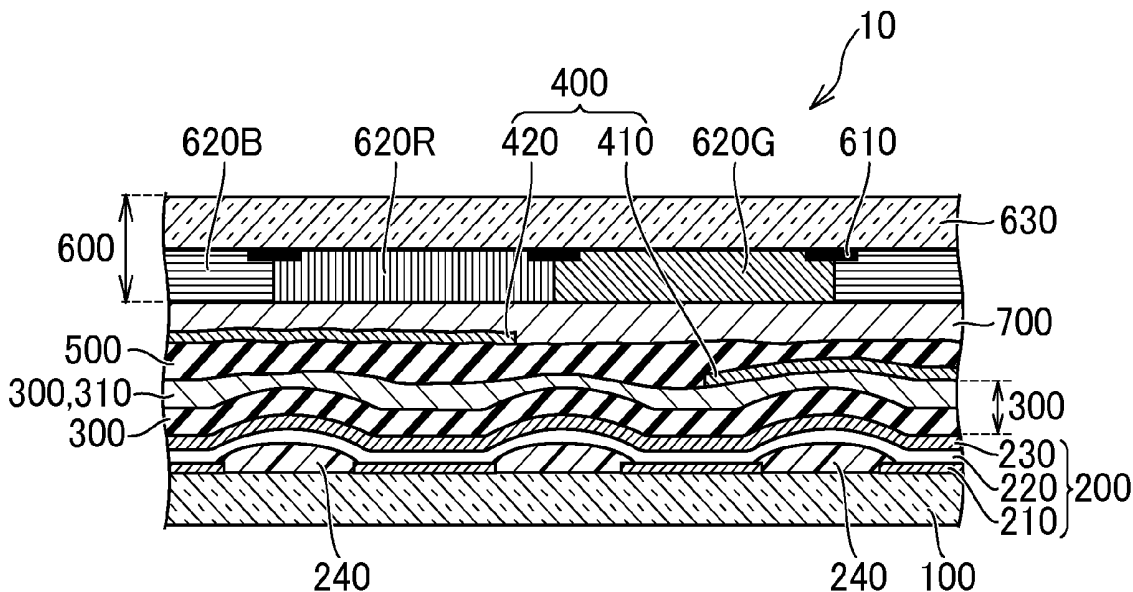

FIG. 1

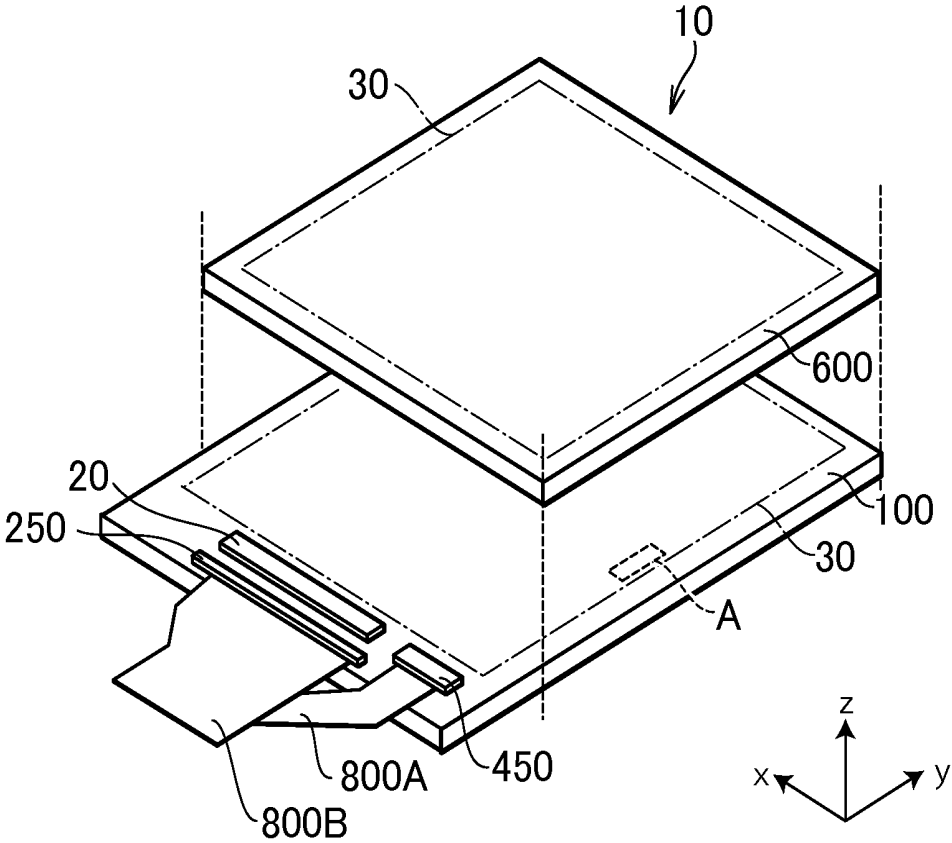

FIG.2

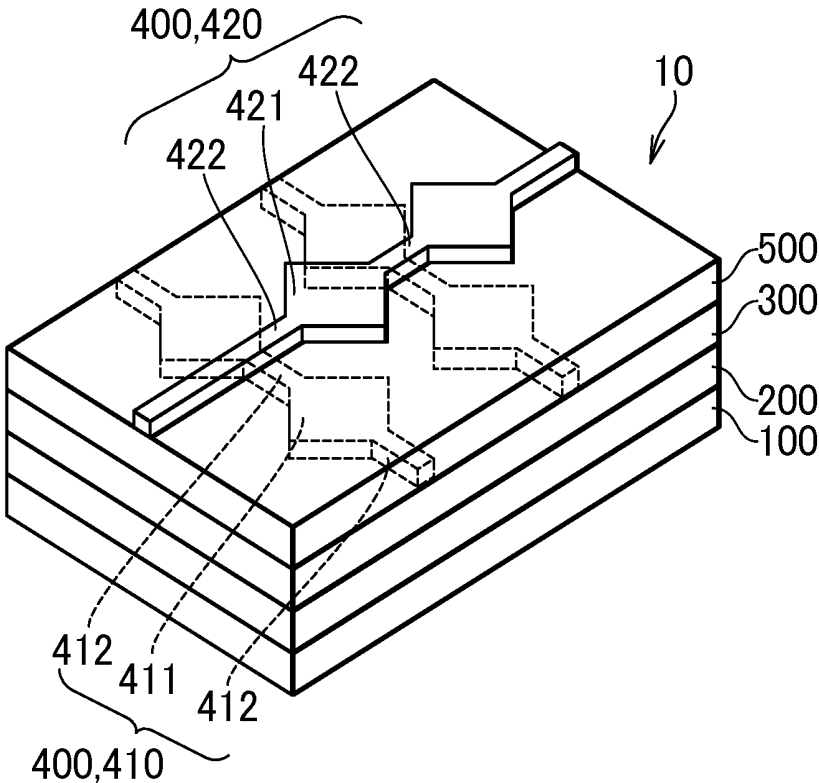

FIG. 3

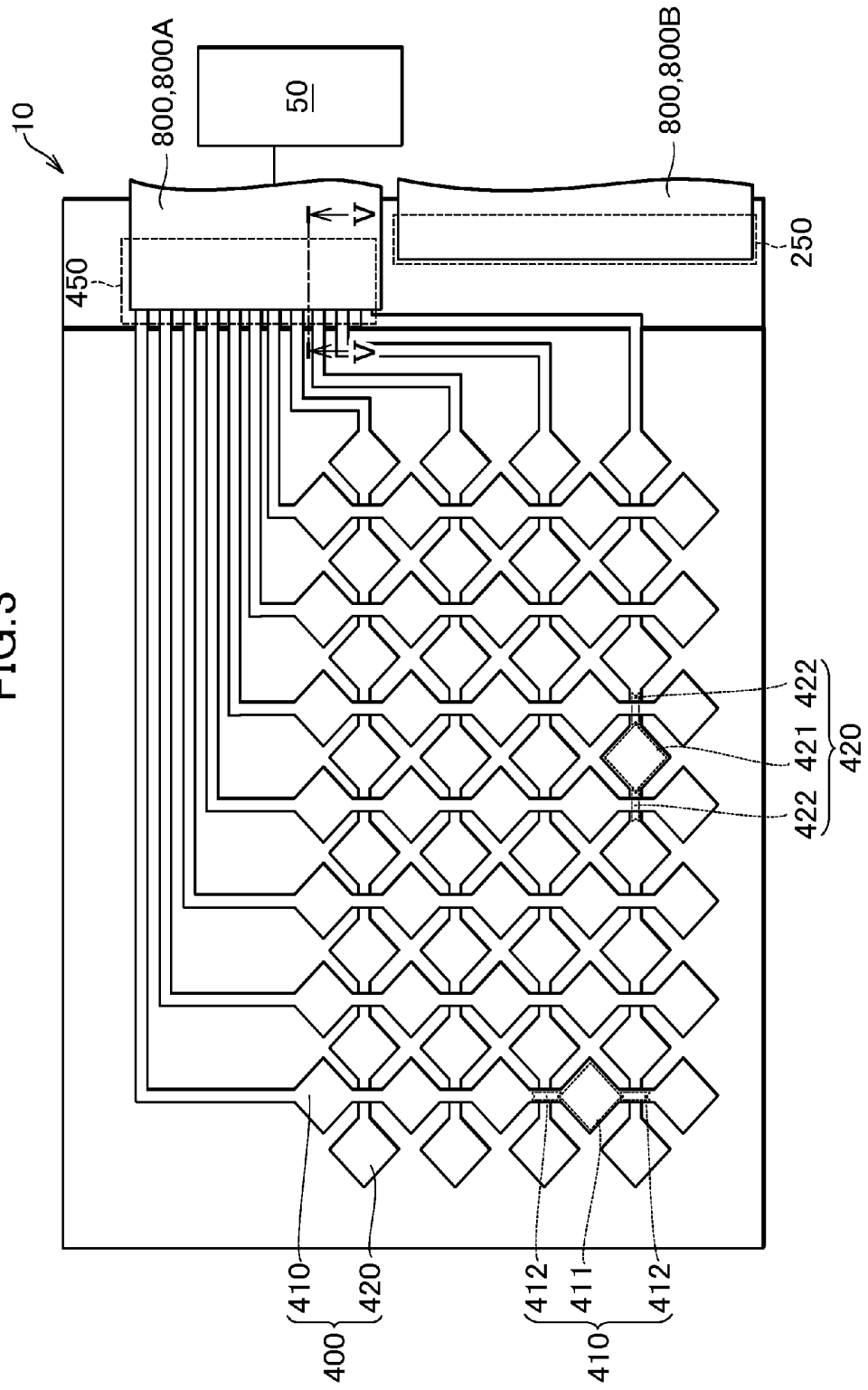

FIG.4A

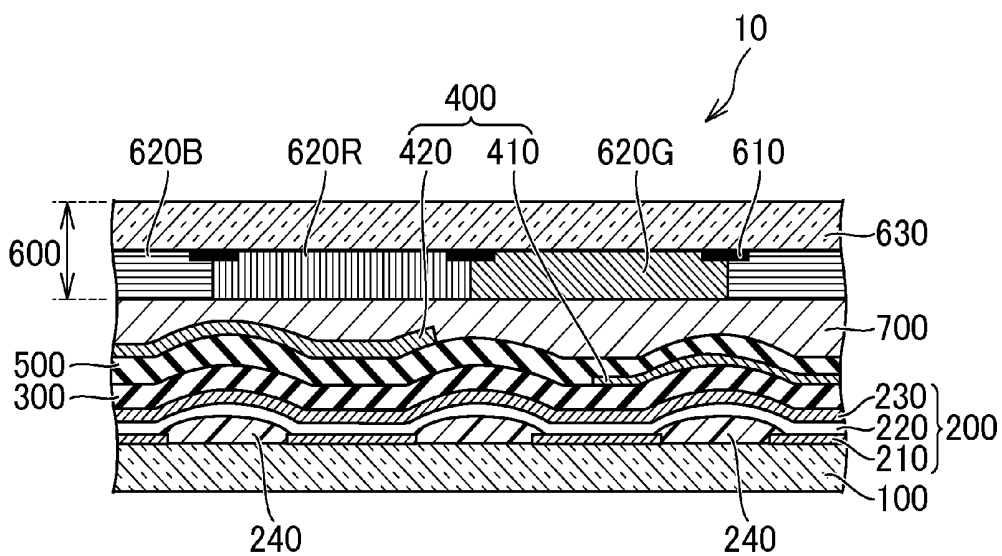

FIG.4B

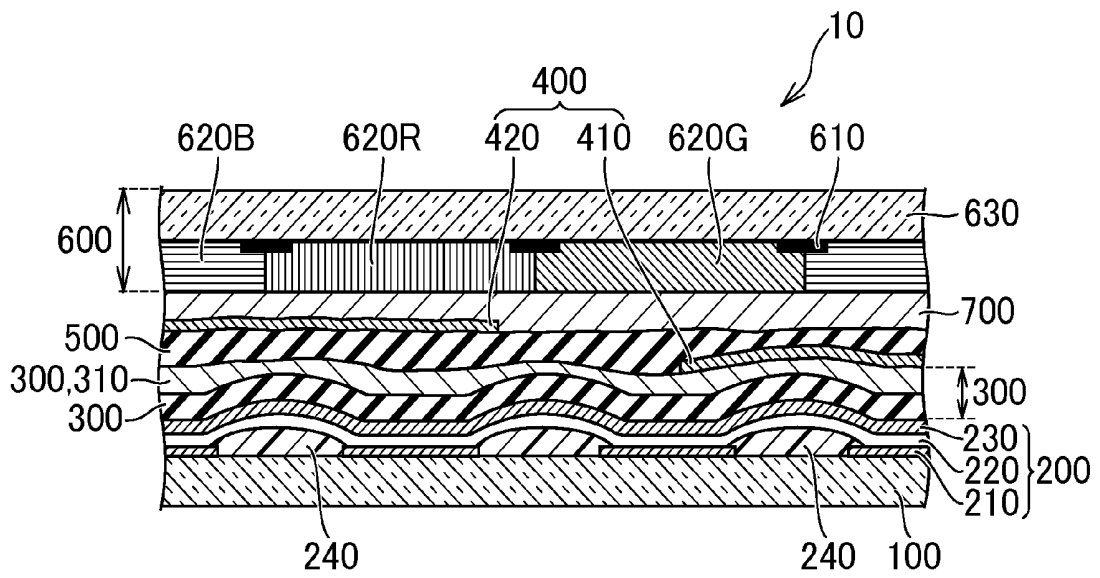

FIG.5A

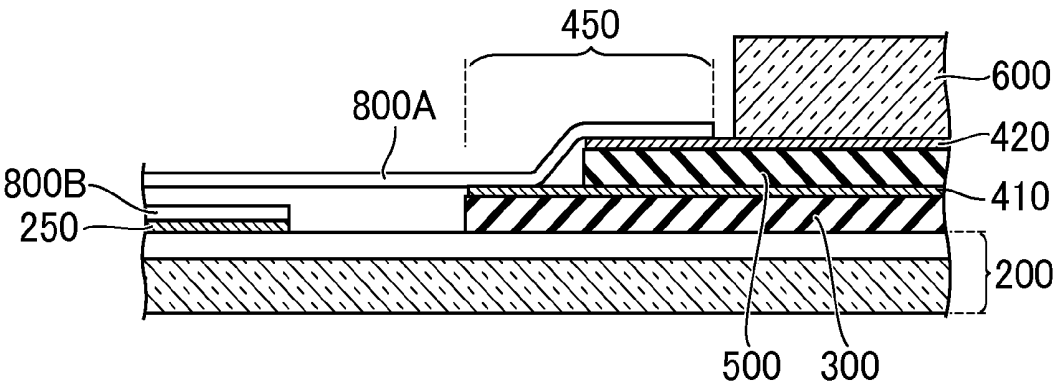

FIG.5B

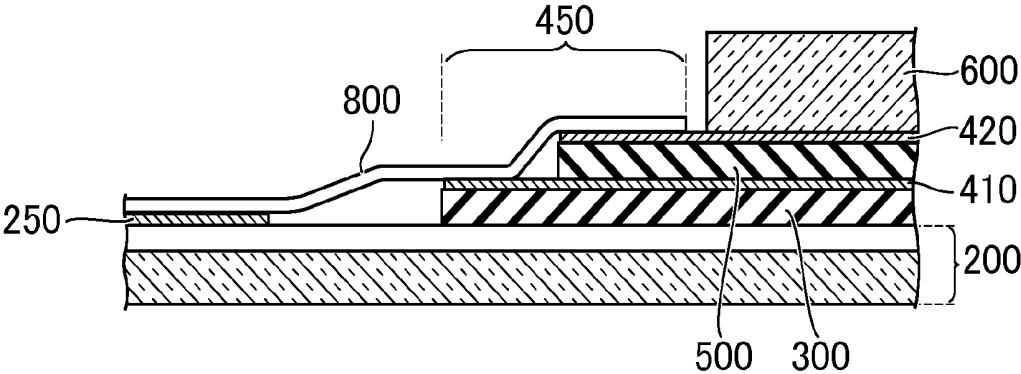

FIG. 6A

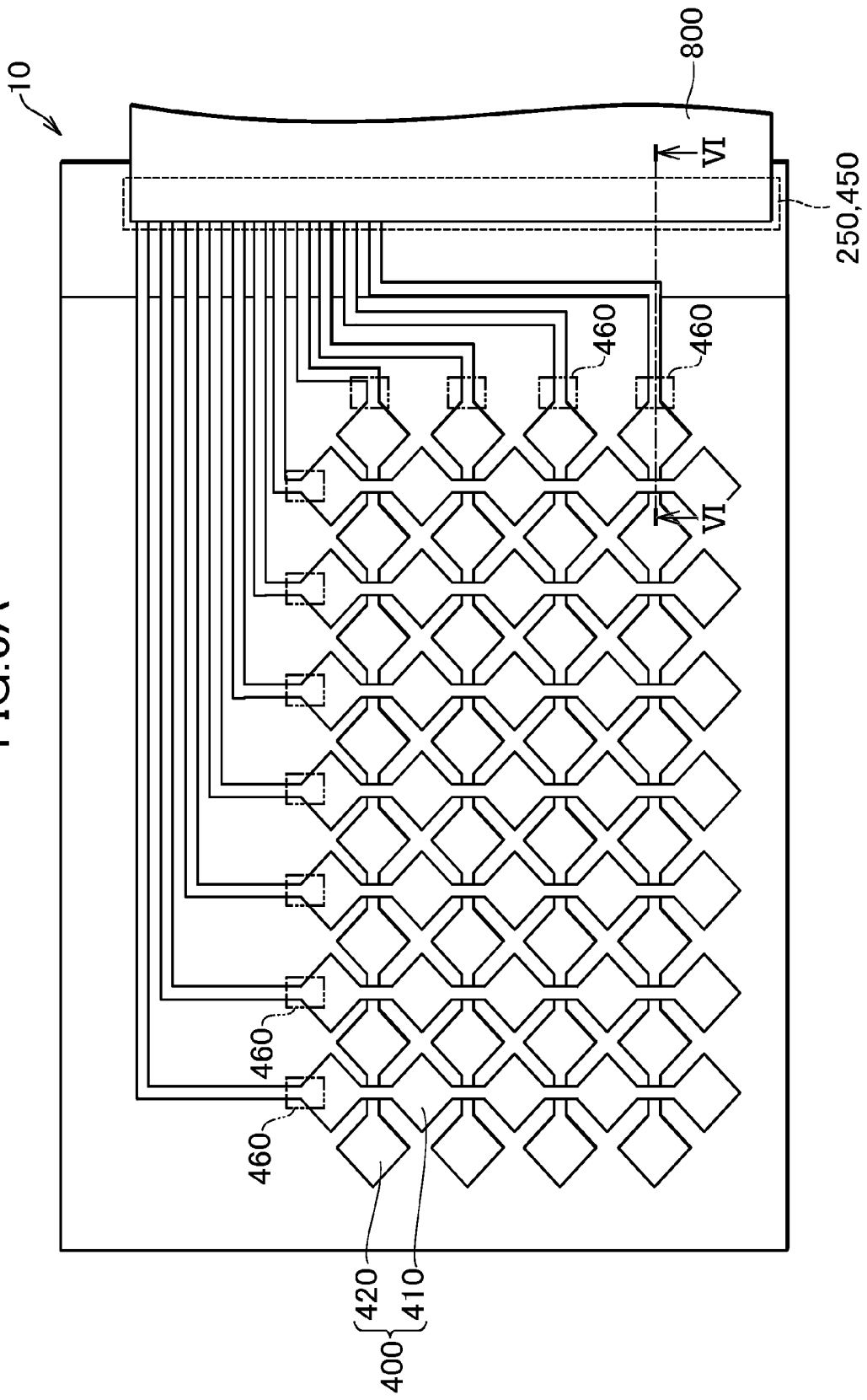
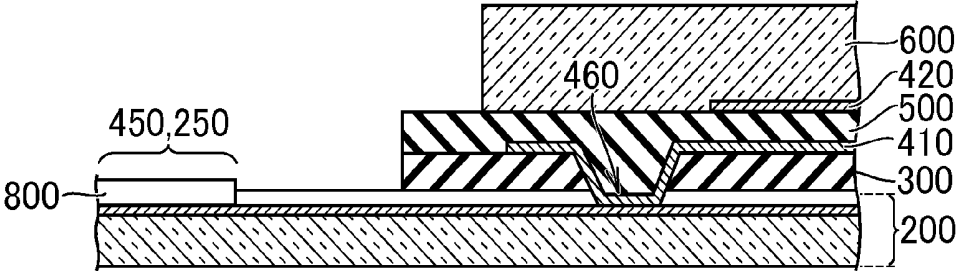

FIG.6B



DISPLAY DEVICE

CROSS-REFERENCE TO RELATED APPLICATION

[0001] The present application claims priority from Japanese patent application JP2013-179505 filed on Aug. 30, 2013, the content of which is hereby incorporated by reference into this application.

BACKGROUND OF THE INVENTION

[0002] 1. Field of the Invention

[0003] The present invention relates to a display device.

[0004] 2. Description of the Related Art

[0005] JP-2012-156140 A discloses an organic light emitting display device including: a substrate; a display part that is formed on the substrate; a sealing substrate having a surface that faces the substrate; a capacitance type touch unit having plural first sensors that are formed on any surface of the sealing substrate to be aligned along a first direction, and plural second sensors that are formed to be aligned in a second direction intersecting the first direction; and an insulating layer that is formed on at least a part of the first sensor and the second sensor, in which the first sensors and the second sensors are formed on any identical surface of the sealing substrate, the plural first sensors and the plural second sensors are made of ITO, formed on the surface of the sealing substrate, sense touch to generate an electric signal, and output electric signals generated in each of the plural first sensors and the plural second sensors of the touch unit through data lines, the display part has thin film transistors formed on the substrate, and organic light emitting elements coupled with the thin film transistors, each of the organic light emitting elements has a counter electrode, a pixel electrode, and an intermediate layer formed between the counter electrode and the pixel electrode, the pixel electrode comes in contact with the thin film transistor, the intermediate layer comes in contact with at least a part of the pixel electrode, the counter electrode comes in contact with at least a part of the intermediate layer, the touch unit is formed directly on one surface of the sealing substrate, and the display part is formed directly on one surface of the substrate.

[0006] Also, JP 2008-216543 A discloses an organic electroluminescent device having an input function, including; an element substrate having a light emitting layer held between a pair of electrodes, a sealing substrate that seals the element substrate; a first detection electrode that is disposed on an inner surface side of the sealing substrate; a second detection electrode that is disposed on an outer surface side of the sealing substrate, and has a detection axis different from that of the first detection electrode, a dielectric film that is laminated on the second detection electrode; and detection means for detecting a formation position of a capacitance formed between the first and second detection electrodes through the dielectric film.

SUMMARY OF THE INVENTION

[0007] As a method giving an input function on a display screen of the organic EL device, a method of appending a touch panel (touch sensor) to a surface of a display screen, and conducting operation by a finger or a pen, as disclosed in, for example, JP 2012-156140 A, and JP 2008-216543 A is realized.

[0008] However, the display device with the touch sensor in which the touch panel is adhered to the surface of the display screen as another member, or provides the touch sensor function in a part of the counter substrate of the display device as disclosed JP 2012-156140 A and JP 2008-216543 A is large in the thickness of the device per se, and hardly satisfies a demand for thinning electronic devices in recent years.

[0009] In view of the above problem, the present inventors have earnestly studied the provision of a display device with a touch sensor which is thinner than the display device with the touch sensor in which the touch panel is adhered to the surface of the display screen as another member, or provides the touch sensor function in a part of the counter substrate of the display device.

[0010] An object of the present invention is to provide an organic electroluminescent device with a touch sensor which is thinner than the display device with the touch sensor in which the touch panel is adhered to the surface of the display screen as another member, or provides the touch sensor function in a part of the counter substrate of the display device.

[0011] Also, the above and other objects, and novel features of the present invention will become apparent from the description of the present specification, and the attached drawings.

[0012] In order to solve the above problem, according to the present invention, there is provided a display device, including: a first substrate in which pixels each having a thin-film transistor are arranged in a matrix on an insulating surface; a second substrate that is arranged opposite to the first substrate; an organic EL element layer that is arranged above the first substrate and between the first substrate and the second substrate, and emits light under control by a circuit including the thin film transistor; a first sealing film which is arranged toward the second substrate of the organic EL element layer, covers the organic EL element layer, and includes at least a first inorganic layer made of inorganic material; a plurality of first detection electrodes that extend in one direction, and are arranged in parallel toward the second substrate of the first sealing film; a second sealing film that is arranged toward the second substrate of the first detection electrodes, and includes at least a second inorganic layer made of an inorganic material; a plurality of second detection electrodes that extend in another direction different from the one direction, and are arranged in parallel toward the second substrate of the second sealing film; and a touch sensor control unit that controls a potential of any one of the first detection electrodes and the second detection electrodes, and detects an electric change generated in the other detection electrodes to detect a touch with a display surface.

[0013] Also, each of the first detection electrodes and the second detection electrodes may have a shape having continuous rectangles (stripes) and/or continuous rhombs (diamonds). Also, each of the first detection electrodes and the second detection electrodes may be formed through any one of a sputtering method and a printing method.

[0014] Also, the first sealing film may have a planarizing layer made of an organic material toward the second substrate of the first inorganic layer.

[0015] Also, the planarizing layer may have a thickness of 1 to 100 μm . Also, a connection terminal for connection with the touch sensor control unit, and a connection terminal for connection with an organic EL element control unit for controlling the light emission of the organic EL element layer may be formed in the same plane of the first substrate.

[0016] According to the present invention, there is provided an organic electroluminescent device with a touch sensor which is thinner than the display device with the touch sensor in which the touch panel is adhered to the surface of the display screen as another member, or provides the touch sensor function in a part of the counter substrate of the display device.

BRIEF DESCRIPTION OF THE DRAWINGS

[0017] FIG. 1 is an exploded perspective view of an organic electroluminescent device with a touch sensor according to a first embodiment of the present invention;

[0018] FIG. 2 is an enlarged diagram illustrating an A portion in FIG. 1, which is a perspective view schematically illustrating an arrangement of detection electrodes included in the organic electroluminescent device with a touch sensor according to the first embodiment of the present invention;

[0019] FIG. 3 is a plan view schematically illustrating the arrangement of the detection electrodes included in the organic electroluminescent device with a touch sensor according to the first embodiment of the present invention;

[0020] FIG. 4A is a cross-sectional view of the organic electroluminescent device with a touch sensor according to the first embodiment of the present invention;

[0021] FIG. 4B is a cross-sectional view of an organic electroluminescent device with a touch sensor according to a second embodiment of the present invention;

[0022] FIG. 5A is a schematic cross-sectional view illustrating a neighborhood of a part taken along a line V-V in FIG. 3;

[0023] FIG. 5B is a cross-sectional view illustrating another example of a neighborhood of a connection terminal portion in a display device according to the present invention;

[0024] FIG. 6A is a plan view schematically illustrating an arrangement of detection electrodes included in an organic electroluminescent device with a touch sensor according to another embodiment of the present invention; and

[0025] FIG. 6B is a schematic cross-sectional view of a neighborhood of a part taken along a line VI-VI in FIG. 6A.

DETAILED DESCRIPTION OF THE INVENTION

First Embodiment

[0026] According to the first embodiment of the present invention, there is provided a display device, including: a first substrate in which pixels each having a thin-film transistor are arranged in a matrix on an insulating substrate; a second substrate that is arranged opposite to the first substrate; an organic EL element layer that is arranged on the first substrate and between the first substrate and the second substrate, and emits light under control by a circuit including the thin film transistor; a first sealing film which is arranged on a side of the organic EL element layer opposite to the second substrate side, and covers the organic EL element layer; a plurality of first detection electrodes that extend in one direction, and are arranged in parallel in a partial area on a side of the first sealing film opposite to the second substrate; a second sealing film that is arranged to cover another area that is an outside of the partial area in which the first detection electrodes are arranged, and a side of the first detection electrodes opposite to the second substrate; a plurality of second detection electrodes that extend in another direction different from the one direction, and are arranged in parallel in a partial area on a

side of the second sealing film opposite to the second substrate; and a touch sensor control unit that controls a potential of any one of the first detection electrodes and the second detection electrodes, and detects an electric change generated in the other detection electrodes to detect a touch with a display surface.

[0027] Hereinafter, a display device according to an embodiment of the present invention will be described with reference to the accompanying drawings. FIG. 1 is an exploded perspective view of an organic electroluminescent device with a touch sensor 10 according to a first embodiment of the present invention.

[0028] As illustrated in FIG. 1, the organic electroluminescent device with a touch sensor 10 according to the first embodiment of the present invention includes a first substrate 100 and a second substrate 600. The organic electroluminescent device with a touch sensor 10 according to the first embodiment of the present invention displays an image on a display surface 30, and incorporates a touch sensor that detects that a finger touches any position of the display surface 30 thereinto.

[0029] A first substrate 100 included in the organic electroluminescent device with a touch sensor 10 according to the first embodiment of the present invention is omitted from FIG. 1, but has a structure in which pixels each having a thin film transistor are arranged in a matrix on an insulating substrate. In this example, the insulating substrate maybe made of, for example, glass, plastic (polycarbonate, polyethylene terephthalate, polyimide, polyacrylate, etc.).

[0030] Also, the first substrate 100 included in the organic electroluminescent device with a touch sensor 10 according to the first embodiment of the present invention may be made of, for example, a light transmissive material. In this example, as the insulating substrate configuring the first substrate 100, the light transmissive material may be glass, plastic (polycarbonate, polyethylene terephthalate, polyimide, polyacrylate, etc.). Also, as wirings and electrodes configuring the first substrate 100, the light transmissive material may be ITO or IZO. Also, the light transmissive material is not limited to the above examples.

[0031] Also, the first substrate 100 on which the circuits each using the thin film transistor are arranged is also called "a TFT (thin film transistor) substrate. In this example, the thin film transistor may include a semiconductor film made of polysilicon, a gate insulating film that covers the semiconductor film, a gate electrode that is arranged above the semiconductor film through the gate insulating film, and a source electrode and a drain electrode that penetrate through the gate insulating film, and are electrically connected to the semiconductor film. Also, as illustrated in FIG. 1, a driver circuit 20 for driving the circuits each using the thin film transistor which are arranged on the first substrate 100 may be arranged on the first substrate 100.

[0032] Also, the second substrate 600 included in the organic electroluminescent device with a touch sensor 10 according to the first embodiment of the present invention may be configured by a color filter substrate having a color filter that transmits alight having a given wavelength region among lights emitted from organic EL elements (refer to FIGS. 2 and 4A) arranged on the first substrate. The second substrate 600 which is the color filter substrate will be described in detail later.

[0033] FIG. 2 is an enlarged diagram illustrating an A portion in FIG. 1, which is a perspective view schematically

illustrating an arrangement of detection electrodes included in the organic electroluminescent device with a touch sensor 10 according to the first embodiment of the present invention.

[0034] As illustrated in FIG. 2, the organic electroluminescent device with a touch sensor 10 according to the first embodiment of the present invention includes a laminated structure in which a first substrate 100 having the circuits each using the thin film transistor, an organic EL element layer 200, a first sealing film 300, first detection electrodes 410 that extend in an X-direction, a second sealing film 500, and second detection electrodes 420 that extend in a Y-direction are laminated on each other in the stated order. Although parts of the first detection electrodes 410 and the second detection electrodes 420 are illustrated in FIG. 2, the plural first detection electrodes 410 and the plural second detection electrodes 420 are arranged in rows over the overall display surface 30.

[0035] Also, as illustrated in FIG. 2, the first detection electrodes 410 are arranged in a part of an area of the first sealing film 300 opposite to a side that comes in contact with the organic EL element layer 200. Also, the first detection electrodes 410, and the other portion of the first sealing film 300 in which the first detection electrodes 410 are not arranged on the first sealing film 300 are covered with the second sealing film 500. The second detection electrodes 420 are arranged in a partial area of the surface of the second sealing film 500.

[0036] The first detection electrodes 410 extending in the X-direction, and the second detection electrodes 420 extending in the Y-direction in FIG. 2 configure a capacitance type projection touch sensor 400. The capacitance type projection touch sensor will be described below.

[0037] Two kinds of a capacitance surface type and a capacitance projection type have been known as the capacitance type touch panel. Both of the capacitance surface type and the capacitance projection type are designed to detect a position at which a fingertip touches while capturing a change in the capacitance between the fingertip and the detection electrode. The touch sensor of the capacitance surface type detects the capacitance with the configuration small in the number of detection terminals such as a solid electrode film and electrode terminals of four corners. On the other hand, the touch sensor of the capacitance projection type employs a multi-point detection system for enhancing the detection sensitivity, and therefore employs a complicated configuration in which a plurality of first detection electrodes 410 extending in the X-direction sterically intersect with a plurality of second detection electrodes 420 extending in the Y-direction.

[0038] An arrangement relationship between the first detection electrodes 410 and the second detection electrodes 420 will be described in more detail. FIG. 3 is a plan view schematically illustrating the arrangement of the detection electrodes included in the organic electroluminescent device with a touch sensor 10 according to the first embodiment of the present invention.

[0039] As illustrated in FIG. 3, the first detection electrodes 410 and the second detection electrodes 420 are configured so that the rectangles (stripes) and/or the rhombi (diamonds) are aligned in lines to provide electrodes extending in the X-direction and the Y-direction, respectively. As compared with a solid electrode employed in the capacitance surface type, although the shape is complicated, the detection sensitivity of the touch sensor 400 is improved with the application of the detection electrodes having the shape in which the rectangles

(stripes) and/or the rhombi (diamonds) are continuously arranged as described above. Therefore, this shape is preferable.

[0040] Also, the first detection electrodes 410 and the second detection electrodes 420 may be configured with the inclusion of main body portions 411 and 421 having the shape of the rectangles (stripes) and/or the rhombi (diamonds), and connection portions 412 and 422 that connect the main body portions 411 and 421 to the adjacent other main body portions 411 and 421.

[0041] Also, as illustrated in FIG. 3, lines led from the first detection electrodes 410 and the second detection electrodes 420 are connected to an external touch sensor control unit 50 through a flexible printed circuit board (FPC) 800A connected to a connection terminal 450 formed on the first substrate 100.

[0042] Also, one end of the first substrate 100 in the organic electroluminescent device with a touch sensor 10 according to the first embodiment of the present invention is equipped with a connection terminal 250 for driving the organic EL element layer 200. The one end of the first substrate 100 is connected to an external organic EL element control unit (not shown) through a flexible printed circuit board (FPC) 800B connected to the connection terminal 250.

[0043] In the organic electroluminescent device with a touch sensor 10 according to the first embodiment of the present invention, the respective connection terminals 450 and 250 connected with the touch sensor control unit 50 and the organic EL element control unit can be disposed on the first substrate 100 of the same plane. Although will be described later, the connection terminal 250 for driving the organic EL element layer 200 may coexist with the connection terminal 450 for touch sensor control provided on the first substrate 100. Also, a method of connecting the connection terminal portions will be described in more detail later.

[0044] Subsequently, the organic EL element layer 200 will be described. FIG. 4A is a cross-sectional view of the organic electroluminescent device with a touch sensor 10 according to the first embodiment of the present invention.

[0045] As illustrated in FIG. 4A, the organic EL element layer 200 including anodes 210, a cathode 230, and a light emitting layer 220 held between the anodes 210 and the cathode 230 is disposed on the first substrate 100.

[0046] Also, sealing films 300 and 500 that protect the organic EL element layer 200 are formed on the organic EL element layer 200, and the respective touch sensors 400 are disposed on the sealing films 300 and 500. That is, the organic EL element layer 200 and the touch sensor 400 are disposed on the first substrate 100.

[0047] Hereinafter, a description will be given of the organic EL element layer 200 included in the organic electroluminescent device with a touch sensor 10 according to the first embodiment of the present invention. The organic EL element layer 200 included in the organic electroluminescent device with a touch sensor 10 according to the first embodiment of the present invention has the anodes 210, the cathode 230, and the light emitting layer 220 held between the anodes 210 and the cathode 230, and is disposed on the above-described first substrate 100.

[0048] The anodes 210 and the cathode 230 in this embodiment may be each formed of a conductive film made of a transparent metal such as ITO or IZO. Each of the anodes 210 included in the organic EL element layer 200 is supplied with a current through the thin film transistor disposed on the first

substrate **100**. The current supplied to the anode **210** flows into the cathode **230** through the light emitting layer **220**. The light emitting layer **220** held between the anode **210** and the cathode **230** emits light by recoupling electrons from the cathode **230** with holes from the anode **210**. The external is irradiated with the emitted light.

[0049] Also, the cathode **230** in this embodiment is formed of a solid electrode formed over the substantially overall surface of the display surface **30** of the organic electroluminescent device with a touch sensor **10**. The solid electrode is formed over the overall surface of a given area (in this embodiment, the display surface **30** of the organic electroluminescent device with a touch sensor **10**). For that reason, even if a disconnection is slightly generated due to an uneven state of the surface, the function of the electrodes is not completely impaired.

[0050] A side of the organic EL element layer **200** opposite to the first substrate **100** side is equipped with the first sealing film **300**. That is, a side, which faces the second substrate **600**, of the cathode **230** located in the uppermost surface of the organic EL element layer **200** is provided with the first sealing film **300**.

[0051] Also, as illustrated in FIG. 4A, banks **240** are formed on ends of the respective anodes **210** included in the organic EL element layer **200** so as to cover the ends thereof. The banks **240** cover the ends of the anodes **210** separated in the respective pixels to perform a function of defining the light emitting areas. Hence, as illustrated in FIG. 4A, the banks **240** are disposed at positions corresponding to a black matrix **610** provided on the color filter substrate (second substrate **600**).

[0052] Also, the respective banks **240** cover the steps of the anode **210** ends formed on the first substrate **100** to perform a function of preventing short circuit between the anodes **210** and the cathode **230**, which is caused by the disconnection of the light emitting layer **220** in the organic EL element layer **200**. For that reason, as illustrated in FIG. 4A, the banks **240** are each formed to have a smooth curve surface.

[0053] For that reason, referring to FIG. 4A, the cathode **230**, which is the solid electrode formed in the uppermost surface of the organic EL element layer **200**, is formed with smooth unevenness following the shape of the banks **240**. A surface of the first sealing film **300** disposed on a side of the organic EL element layer **200** opposite to the first substrate **100** side is also formed with unevenness following the surface shape of the cathode **230** which is the solid electrode formed in the uppermost surface of the organic EL element layer **200**.

[0054] In this example, the first sealing film **300** is disposed for protecting the organic EL element layer **200** from moisture and oxygen from the external. Therefore, a material of the first sealing film **300** is selected taking water permeability and air permeability into account.

[0055] In this embodiment, the first sealing film **300** is formed of a first inorganic layer made of an inorganic material. Also, the first inorganic layer may be made of a compound selected from a compound group consisting of SiN, SiO₂, P₂O₅, SiO₂(PSG), Al₂O₃, PbO.SiO₂, Si₃N₄, SiON, and PbO.B₂O₃. It is preferable that the first sealing film **300** is made of SiN among those components. Also, the first sealing film **300** may be formed through, for example, CVD. The material and the forming method of the first sealing film **300** are not limited to those described above.

[0056] A thickness of the first sealing film **300** may be set to 0.5 to 5 μm. When the thickness of the first sealing film **300**

may be set to 0.5 to 5 μm, the effect of protecting the organic EL element layer **200** is enhanced, which is preferable.

[0057] Because the first detection electrodes **410** formed on the first sealing film **300** configures the capacitance type projection touch sensor **400**, the first detection electrodes **410** have a complicated shape such that, for example, rectangles (stripes) and/or the rhombi (diamonds) are aligned in lines as described above. For that reason, the first detection electrodes **410** become in an open state when the disconnection is generated unlike the solid electrode, and the function of the touch sensor **400** may be completely impaired. Therefore, the surface of the first sealing film **300** is required to be flatter so that the first detection electrodes **410** are not disconnected.

[0058] Also, in particular, places in which the banks **240** are formed increase more as the organic electroluminescent display unit provided in the organic electroluminescent device with a touch sensor **10** becomes higher definition. As a result, the unevenness is liable to be more formed.

[0059] Also, the second sealing film **500** is provided for protecting the organic EL element layer **200** from moisture or oxygen from the external as in the first sealing film **300**. Therefore, a material of the second sealing film **500** is selected taking water permeability and air permeability into account.

[0060] The second sealing film **500** according to this embodiment is formed of a second inorganic layer made of an inorganic material. Also, the second inorganic layer maybe made of a compound selected from a compound group consisting of SiN, SiO₂, P₂O₅, SiO₂(PSG), Al₂O₃, PbO.SiO₂, Si₃N₄, SiON, and PbO.B₂O₃. The second sealing film **500** is made of an organic material, but may be made of, for example, polyimide resin and/or derivative thereof. It is preferable that the first sealing film **300** is made of SiN among those components. Also, the second sealing film **500** may be formed through, for example, CVD. The material and the forming method of the second sealing film **500** are not limited to those described above.

[0061] Also, a thickness of the second sealing film **500** may be set to 0.5 to 5 μm. When the thickness of the second sealing film **500** may be set to 0.5 to 4 μm, the effect of protecting the organic EL element layer **200** is enhanced, which is preferable.

[0062] The second detection electrodes **420** formed on the second sealing film **500** have a complicated shape such that, for example, rectangles (stripes) and/or the rhombi (diamonds) are (continuously) aligned in lines as described above. For that reason, it is preferable that the surface of the second sealing film **500** on which the second detection electrodes **420** are formed is flat. This is because it is conceivable that the second detection electrodes **420** are disconnected by the unevenness of the surface of the second sealing film **500**.

[0063] Also, the respective thicknesses of the first detection electrodes **410** and the second detection electrodes **420** may be set to 10 to 100 μm. When the respective thicknesses of the first detection electrodes **410** and the second detection electrodes **420** may be set to 10 to 100 μm, a sheet resistance can be reduced, which is preferable.

[0064] Also, the first detection electrodes **410** and the second detection electrodes **420** included in the organic electroluminescent device with a touch sensor **10** according to the first embodiment of the present invention may be formed through any one of a mask sputtering method and a printing method.

[0065] The organic electroluminescent device with a touch sensor **10** according to the first embodiment of the present invention incorporates the capacitance projection type touch panel for the purpose of enhancing the detection sensitivity. In order to realize the touch panel, there is a need to pattern the complicated shape illustrated in FIG. 3. Also, in the organic electroluminescent device with a touch sensor **10** according to the present invention, the organic EL element layer **200** and the touch sensor **400** are physically located at a short distance as illustrated in FIG. 4A in response to a request for thinning. Taking the above into account, it is preferable to employ a method in which the touch sensor **400** is formed preferably without using moisture and oxygen because the organic EL element layer **200** hate moisture and oxygen.

[0066] For example, the method of forming the detection electrodes through etching is not preferable in the formation of the first detection electrodes **410** and the second detection electrodes **420** in the organic electroluminescent device with a touch sensor **10** according to the first embodiment of the present invention because the method uses a large amount of waters for washing an etchant. Therefore, it is preferable that the first detection electrodes **410** and the second detection electrodes **420** included in the organic electroluminescent device with a touch sensor **10** according to the first embodiment of the present invention are each formed through any one of the sputtering method and the printing method. In the present specification, the printing method is, for example, an inkjet method or a letterpress printing method.

[0067] Also, when the first detection electrodes **410** and/or the second detection electrodes **420** are formed through the mask sputtering method, if there is no space between the mask and the substrate, an influence of scratch or foreign matter is conceivable. For that reason, it is preferable that a given space is created between the mask and the substrate to form the first detection electrodes **410** and/or the second detection electrodes **420**. When the given space is created between the mask and the substrate to form the first detection electrodes **410** and/or the second detection electrodes **420**, the ends of the first detection electrodes **410** and/or the second detection electrodes **420** are tapered. Therefore, the ends of the first detection electrodes **410** and/or the second detection electrodes **420** may be tapered.

[0068] Also, the first detection electrodes **410** and the second detection electrodes **420** may be each made of a transparent metal such as ITO or IZO, or a metal mesh, silver nanofibers, carbon nanofibers, or graphene.

[0069] The color filter substrate which is the second substrate **600** according to this embodiment may be of a structure in which three areas (**620R**, **620G**, **620B**) partitioned by RGB are formed on a transparent substrate **630** made of glass or resin. Also, a filling layer **700** made of, for example, an organic resin may be disposed between the second substrate **600** and the second detection electrodes **420**.

[0070] As compared with the organic electroluminescent device having no touch sensor, the organic electroluminescent device with a touch sensor according to the first embodiment as described above can be realized by only an increase in the thickness of a sealing film structure including the first and second detection electrodes substantially configuring the touch sensor, and fulfills the request for thinning.

[0071] Also, a description will be given of a method of connecting the connection terminal portions in detail below. FIG. 5A is a schematic cross-sectional view illustrating a neighborhood of a part taken along a line V-V in FIG. 3. As

illustrated in FIG. 5A, the connection terminal **450** of the touch sensor **400**, and the connection terminal **250** of the organic EL element layer **200** provided in the organic electroluminescent device with a touch sensor **10** are formed on the same substrate (on the first substrate **200**).

[0072] As illustrated in FIG. 5A, the first sealing film **300** and the second sealing film **500** are removed on ends thereof in stages. With this configuration, one end of the first detection electrodes **410** and one end of the second detection electrodes **420** are exposed as the connection terminal **450** of the touch sensor **400**. That is, the connection terminal **450** of the touch sensor **400** is configured by one end of the first detection electrodes **410**, and one end of the second detection electrodes **420**.

[0073] A flexible printed circuit board (FPC) **800A** connected to the connection terminal **450** of the touch sensor **400** is connected to one end of the first detection electrodes **410**, and one end of the second detection electrodes **420**. Also, the connection terminal **250** of the organic EL element layer **200** is connected to another flexible printed circuit board (FPC) **800B** different from the flexible printed circuit board (FPC) **800A** connected to the connection terminal **450** of the touch sensor **400**.

[0074] FIG. 5B is a cross-sectional view illustrating another example of a neighborhood of a connection terminal portion in the display device **10** according to the present invention. As illustrated in FIG. 5B, the connection terminal **450** of the touch sensor **400** and the connection terminal **250** of the organic EL element layer **200** are connected to a common flexible printed circuit board (FPC) **800**.

[0075] As described above, the connection terminal **450** of the touch sensor **400** and the connection terminal **250** of the organic EL element layer **200** are connected to one flexible printed circuit board (FPC) **800**, thereby being capable of simplifying the connecting process, and reducing the members. As a result, a reduction in the manufacture cost is realized.

[0076] FIG. 6A is a plan view schematically illustrating an arrangement of detection electrodes included in an organic electroluminescent device with a touch sensor **10** according to another embodiment of the present invention. FIG. 6B is a schematic cross-sectional view of a neighborhood of a part taken along a line VI-VI in FIG. 6A. FIG. 6B is a cross-sectional view illustrating another example of a neighborhood of the connection terminal portion in the organic electroluminescent device with a touch sensor **10** according to the present invention.

[0077] As illustrated in FIG. 6B, the first detection electrodes **410** and the second detection electrodes **420** which configure the touch sensor **400** are electrically connected to lead lines connected to the connection terminal **450** disposed on the first substrate **100**, through a contact hole **460** formed in ends of those detection electrodes.

[0078] With the application of the above structure, the connection terminal **450** of the touch sensor **400** and the connection terminal **250** of the organic EL element layer **200** are formed in the same plane of the first substrate **200**. For that reason, the electric connection with the external circuit is further facilitated.

[0079] Also, the organic electroluminescent device with a touch sensor connected to the contact hole **460** as described above fulfills a request for thinning, and has the effect of facilitating the electric connection with the external circuit.

Second Embodiment

[0080] Hereinafter, a description will be given an embodiment in which even if a higher-definition organic electroluminescent display unit is applied to the organic electroluminescent device with a touch sensor 10, the disconnection of the detection electrodes configuring the touch sensor is suppressed while thinning the device.

[0081] An organic electroluminescent device with a touch sensor 10 according to a second embodiment of the present invention is different from the organic electroluminescent device with a touch sensor 10 according to the first embodiment in that the first sealing film 300 is configured by the first sealing film 300 and a first planarizing layer 310.

[0082] FIG. 4B is a cross-sectional view of the organic electroluminescent device with a touch sensor 10 according to the second embodiment of the present invention. As illustrated in FIG. 4B, the first sealing film 300 of the organic electroluminescent device with a touch sensor 10 according to the second embodiment has the first planarizing layer 310 that is formed on the second substrate side of the first sealing film 300, and flattens the unevenness of the surface.

[0083] In this example, the first planarizing layer 310 is made of an organic material. The first planarizing layer 310 is provided for the purposes of planarizing the unevenness of a surface of a side of the first sealing film 300 where the first detection electrodes 410 is disposed, and reducing an influence of a capacitance formed between the first planarizing layer 310 and the cathode 230. Therefore, the thickness of the first planarizing layer 310 may be appropriately selected. When varnish (liquid material in which organic resin is dissolved in a solvent) of organic resin is coated on an uneven surface whereby the varnish preferentially flows into a concave portion to effectively flatten the unevenness of the surface of the first sealing film 300.

[0084] Also, the first planarizing layer 310 may be made of, for example, an organic resin. The organic resin applied to the first planarizing layer 310 may be selected from a group consisting of, for example, acrylic, polyimide, epoxy, and an optically clear adhesive (OCA). Apart from the method of coating the organic material, the organic material may be formed by a low-temperature vapor deposition method or a resin sheet sticking method. Also, the first planarizing layer 310 may be gradually thinned toward the outside from the display surface 30, and the first sealing film 300 may come in contact with the second sealing film 500 on the outermost portion. With this configuration, the penetration of moisture from the external can be effectively prevented.

[0085] Also, the first planarizing layer 310 may have a thickness of 1 to 100 μm . It is preferable to set the first planarizing layer 310 to 10 μm or higher because the effect of suppressing the disconnection of the touch sensor is enhanced, and an influence of the capacitance between the cathode 230 and the touch sensor 400 can be reduced. Also, although an upper limit of the thickness of the first planarizing layer 310 is not particularly defined, because an increase in the thickness of the first planarizing layer 310 is disadvantageous to thinning, the upper limit of the thickness may be set to, for example, be equal to or lower than 80 μm , or lower than 80 μm .

[0086] The material and the forming method of the first planarizing layer 310 are not limited to those described above.

[0087] As compared with the organic electroluminescent device having no touch sensor, the organic electrolumines-

cent device with a touch sensor according to the second embodiment as described above can be realized by only an increase in the thickness of the first and second detection electrodes substantially configuring the touch sensor, and the thickness of the first planarizing layer, and fulfills the request for thinning. Also, the organic electroluminescent device with a touch sensor according to the second embodiment has the effect of suppressing the disconnection of the touch sensor, and also the effect of enhancing the reliability of the device.

[0088] Also, the organic electroluminescent device with a touch sensor according to the second embodiment as described above may employ the connection structure of the connection terminal described in the organic electroluminescent device with a touch sensor according to the first embodiment.

[0089] Also, the second sealing film 500 may have a second planarizing layer (not shown) that flattens the unevenness of the surface in an area where at least the second detection electrode 420 is arranged, on a side facing the second substrate 600.

[0090] Also, when the second sealing film 500 has the second planarizing layer, the second planarizing layer may be made of, for example, an organic resin. Because the second planarizing layer is provided for the purpose of planarizing the unevenness of the surface, there is no need to select any material taking water permeability and air permeability, which are functions of the second flattening layer, into account. Also, when varnish (liquid material in which organic resin is dissolved in a solvent) of organic resin is coated on an uneven surface whereby the varnish preferentially flows into a concave portion with the result that the unevenness of the surface of the second sealing film 500 can be effectively flattened, which is preferable.

[0091] The material and the forming method of the second planarizing layer are not limited to those described above.

[0092] Also, the second planarizing layer may have a thickness of 1 to 100 μm . It is preferable to set the second planarizing layer to 10 μm or higher because the effect of suppressing the disconnection of the touch sensor is enhanced. Also, although an upper limit of the thickness of the second planarizing layer is not particularly defined, because an increase in the thickness of the second planarizing layer is disadvantageous to thinning, the upper limit of the thickness may be set to, for example, be equal to or lower than 80 μm , or lower than 80 μm .

[0093] While there have been described what are at present considered to be certain embodiments of the invention, it will be understood that various modifications may be made thereto, and it is intended that the appended claim cover all such modifications as fall within the true spirit and scope of the invention.

What is claimed is:

1. A display device, comprising:

a first substrate in which pixels each having a thin-film transistor are arranged in a matrix on an insulating surface;

a second substrate that is arranged opposite to the first substrate;

an organic EL element layer that is arranged above the first substrate and between the first substrate and the second substrate, and emits light under control by a circuit including the thin film transistor;

- a first sealing film which is arranged toward the second substrate of the organic EL element layer, covers the organic EL element layer, and includes at least a first inorganic layer made of inorganic material;
- a plurality of first detection electrodes that extend in one direction, and are arranged in parallel toward the second substrate of the first sealing film;
- a second sealing film that is arranged toward the second substrate of the first detection electrodes, and includes at least a second inorganic layer made of an inorganic material;
- a plurality of second detection electrodes that extend in another direction different from the one direction, and are arranged in parallel toward the second substrate of the second sealing film; and
- a touch sensor control unit that controls a potential of any one of the first detection electrodes and the second detection electrodes, and detects an electric change generated in the other detection electrodes to detect a touch with a display surface.
2. The display device according to claim 1, wherein each of the first detection electrodes and the second detection electrodes has a shape having continuous rectangles (stripes) and/or continuous rhombi (diamonds).
3. The display device according to claim 1, wherein each of the first detection electrodes and the second detection electrodes is formed through any one of a sputtering method and a printing method.
4. The display device according to claim 1, wherein the first sealing film has a planarizing layer made of an organic material toward the second substrate of the first inorganic layer.
5. The display device according to claim 4, wherein the planarizing layer has a thickness of 1 to 100 μm .
6. The display device according to claim 1, wherein a connection terminal for connection with the touch sensor control unit, and a connection terminal for connection with an organic EL element control unit for controlling the light emission of the organic EL element layer are formed in the same plane of the first substrate.
- * * * * *

| | | | |
|----------------|--|---------|------------|
| 专利名称(译) | 显示设备 | | |
| 公开(公告)号 | US20150060817A1 | 公开(公告)日 | 2015-03-05 |
| 申请号 | US14/469634 | 申请日 | 2014-08-27 |
| [标]申请(专利权)人(译) | 株式会社日本显示器 | | |
| 申请(专利权)人(译) | 日本展示INC. | | |
| 当前申请(专利权)人(译) | 日本展示INC. | | |
| [标]发明人 | SATO TOSHIHIRO ITO RYOICHI | | |
| 发明人 | SATO, TOSHIHIRO ITO, RYOICHI | | |
| IPC分类号 | H01L27/32 | | |
| CPC分类号 | H01L27/323 H01L27/3253 G06F3/0445 G06F3/0446 H01L27/3276 H01L51/5203 H01L51/5253 H05K1/118 G06F3/044 H01L51/5225 H01L51/5246 | | |
| 优先权 | 2013179505 2013-08-30 JP | | |
| 其他公开文献 | US9660003 | | |
| 外部链接 | Espacenet USPTO | | |

摘要(译)

一种具有触摸传感器的有机电致发光器件，包括：第一基板；与第一基板相对设置的第二基板；有机EL元件层，配置在第一基板上；第一密封膜，其朝向有机EL元件层的第二基板布置，覆盖有机EL元件层，并包括第一无机层；多个第一检测电极在一个方向上延伸，并且平行地布置在第一密封膜的第二基板上；第二密封膜，其朝向第一检测电极的第二基板布置，并包括第二无机层；多个第二检测电极在与该一个方向不同的另一个方向上延伸，并且平行地布置在第二密封膜的第二基板上；触摸传感器控制单元控制检测与显示表面的触摸的电位。

